



...the passion for moving

La Zallys, è stata fondata da un gruppo di professionisti che hanno saputo sviluppare al meglio Prodotti per un mercato sempre più attento al miglioramento delle condizioni di lavoro e salute ambientale. La nostra etica costruttiva ci impone soluzioni tecniche d'avanguardia, con materiali d'alta qualità che permettono una durata maggiore ed una ridotta manutenzione negli anni. La continua ricerca e miglioramento dei nostri prodotti, la qualità, il design Made in Italy ed un' estrema cura seguita con professionalità ci ha fatto diventare Leaders mondiali nel mercato del veicolo elettrico, garantendo un ottimo rapporto qualità-prezzo, curando l'allestimento sia di servizi post-vendita rapidi ed efficienti, sia di una task-force di assistenza capace di soddisfare ogni esigenza del cliente. Il nostro know-how ha fatto sì da poter vantare una vasta gamma di veicoli applicabili a qualsiasi settore. Inoltre mantenendo la nostra versatilità e creatività siamo sempre a disposizione nel cooperare allo sviluppo di nuovi progetti per un mercato sempre più esigente.

Zallys was founded by a group of professional engineers with a desire to improve the working environment by the introduction of time and labour saving eco friendly equipment. This aim has produced a constant stream of high quality inspired designs, all powered by the ever more efficient electric motor. This now gives us clean, reliable equipment with the advantage of low maintenance for many years to come. The continuous research and improvement in the design of our products, together with the Italian flair for design and professionalism has made us world leaders in the electric vehicle market. The combination of good quality, competitive pricing, rapid and efficient after sales service and a focused sales team ensures that we are well positioned to satisfy any client demand. Our know-how has made it possible to design a diverse range of vehicles that can be used safely in any area. Using our versatility, expertise and creativity, we remain always ready to co-operate with customers to help develop new products for an ever more demanding market.

Zallys a été fondé par un groupe de personnes qualifiées qui ont réussi à développer des Produits créés pour améliorer les conditions du travail, respectant l'environnement. La recherche constante et l'amélioration de nos produits, la qualité, le design Made in Italy et le soin apporté avec professionnalisme, nous ont fait devenir les Leaders mondiaux dans le marché du véhicule électrique, garantissant un rapport optimal entre qualité et prix, et faisant attention autant au service après-vente, rapide et efficace, qu'à un service d'assistance capable de satisfaire toute exigence du client. Notre savoir faire nous a donné le pouvoir de créer une large gamme de véhicules qu'il est possible d'employer dans n'importe quel secteur. En outre, suivant notre éclectisme et notre créativité, nous sommes toujours disponibles pour coopérer au développement de nouveaux projets, pour un marché de plus en plus exigeant.

Zallys ha sido fundada por un grupo de profesionales que ha sabido desarrollar de la mejor forma productos para un mercado siempre más atento al mejoramiento de las condiciones de trabajo y a la salud del medioambiente. Nuestra ética de construcción nos impone soluciones técnicas de vanguardia, con materiales de alta calidad que permiten una duración mayor y un mantenimiento reducido con el pasar de los años. La investigación y el mejoramiento continuos de nuestros productos, la calidad, el diseño made in Italy y el cuidado extremo garantizado por un equipo de profesionales, nos han permitido convertirnos en líderes mundiales en el mercado de los vehículos eléctricos, asegurando una óptima relación calidad precio, la prestación de servicios pos-venta rápidos y eficientes, y la formación de un equipo de asistencia que puede responder a cualquier demanda del cliente. Gracias a nuestros conocimientos hemos desarrollado una amplia gama de vehículos de gran éxito, que se pueden utilizar en cualquier sector. Además la empresa pone a disposición de sus clientes la versatilidad y la creatividad que nos caracterizan, para cooperar al desarrollo de nuevos proyectos destinados a un mercado siempre más exigente y que cambia constantemente.

Zallys ist ein von Fachleuten gegründetes Unternehmen, das sich darin versteht, Produkte für einen Markt zu entwickeln, der den Arbeitsbedingungen und dem Umweltschutz einen immer größeren Stellenwert einräumt. Aufgrund der konstruktiven Ethik des Unternehmens werden technisch hochwertige Produkte entwickelt, bei denen Materialien höchster Qualität eingesetzt werden. Dies erhöht die Laufzeit der Produkte und reduziert deren Wartungsaufwand. Durch die kontinuierliche Forschung und Verbesserung der Produkte, der Qualität, des Designs "Made in Italy" und der äußersten Sorgfalt bei der Herstellung, die von einem Stab von Fachleuten garantiert wird, konnte Zallys zum weltweit führenden Unternehmen im Marktbereich Elektrofahrzeuge aufsteigen. Dabei stellt Zallys sicher, dass ein optimales Preis-Leistungs-Verhältnis, ein schneller und effizienter Kundendienst sowie eine technische Arbeitsgruppe, die alle Kundenansprüche zufrieden stellt, vorhanden sind. Dank des unternehmenseigenen Know-how wurde mit großem Erfolg eine breite Produktpalette an Fahrzeugen entwickelt, die in jedem Bereich einsetzbar ist. Zallys stellt seinen Kunden außerdem seine eigene Vielseitigkeit und Kreativität zur Verfügung, um neue Projekte für einen immer anspruchsvolleren und in ständiger Veränderung befindlichen Markt zu entwickeln.



...the passion for moving



XT 540

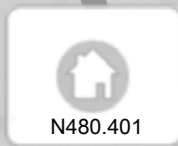

www.zallys.com

Via Palazzina, 1 - 36030 SARCEDO (VI) Italy - Tel. +39 0445.366785 - Fax +39 0445.382552 - info@zallys.com

ELECTRIC VEHICLE • MADE IN ITALY

XT 540



...the passion for moving

ZALLYS XT 540 - è un veicolo elettrico con una solida struttura che garantisce un facile controllo durante la fase di scorrimento di carichi fino a 450Kg, in tutta sicurezza. Il telaio è leggero e completamente in alluminio, quindi pratico e allo stesso tempo forte. L'XT540 è facilmente trasportabile grazie ai suoi 3 elementi principali scomponibili, un singolo operatore è in grado di assemblare la struttura in 60 secondi. Può essere posizionato a distanze variabili che vanno da un minimo di 2m. fino ad un massimo di 4,5m. L'XT540 ha un paranco elettrico alimentato da un carrello in acciaio verniciato contenente due batterie ed un motore da 800W. Grazie alle sue ruote pneumatiche a bassa pressione può operare sia in aree interne che esterne. Le dimensioni dell'XT 540 sono 4000 mm di Lunghezza, 1500 mm di Larghezza 2960 mm di Altezza max. Tutti i veicoli Zallys sono costruiti con materiale di alta qualità garantiti e certificati CE secondo le normative europee.

ZALLYS XT 540 - It is an electric unit designed mainly for the cemetery application and with a solid structure guarantee an easy control during the handling of loads up to 400Kg. in total safety. The light chassis completely in aluminium is very light and practical but resistant at the same time. The XT540 can be easily moved from one place to another also due to the possibility of disassemble it in three principal elements therefore a single operator is capable of assemble the unit in 60 seconds. It can be positioned to variable distances that goes from a minimum of 2 mt. up to a 4,5 mt max. The XT540 has an electric block and tackle powered by a painted steel trolley equipped with 2 batteries and a motor 800W. thank to it's pneumatic low pressure wheels it can work inside as outside. The XT540 dimensions are 4508 mm of length, 1480 mm of width. 2853 of max. height. The unit is guaranteed and CE certified following the European Normative for the safety. All Zallys vehicles are Made with high quality materials guaranteed and CE certified following the European Normative.

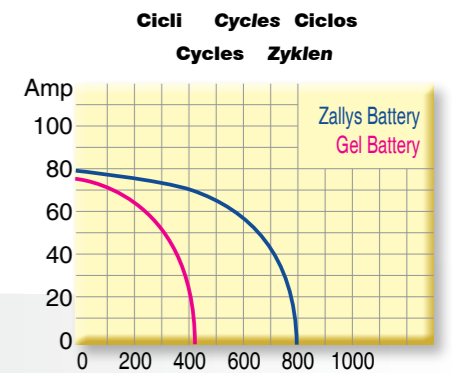
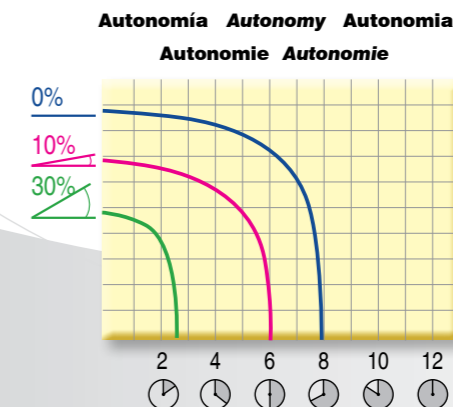
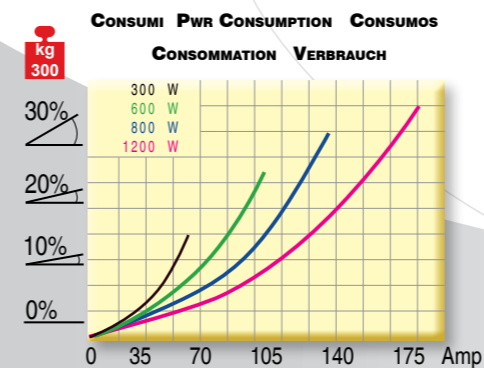
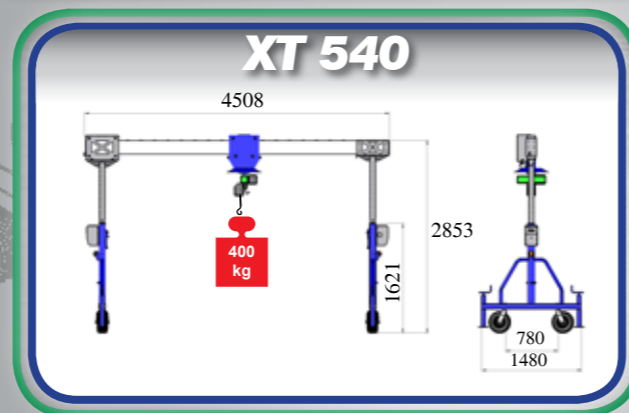
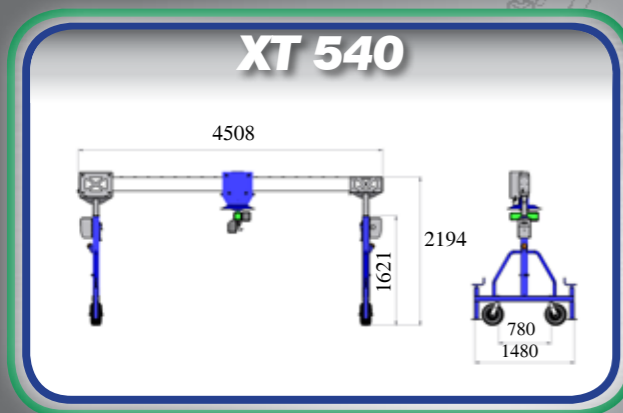
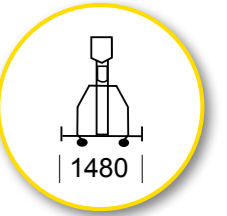
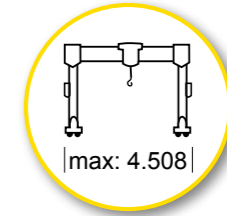
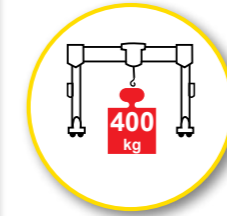
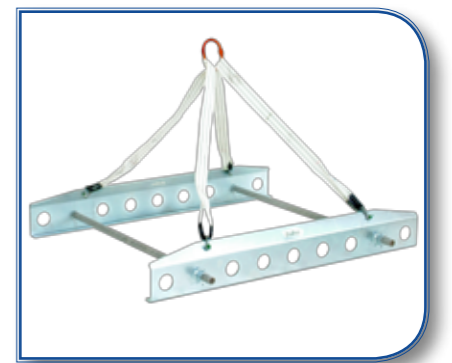

www.zallys.com

